

BOSCH

Invented for life

UHI-SBG-0 Series Indoor Housing



- ▶ Economical indoor housing with mount
- ▶ Aluminum mount included
- ▶ Feed-through wiring option
- ▶ Glass fiber reinforced ABS
- ▶ Accommodates 1/4-inch, 1/3-inch, and 1/2-inch CCD cameras

The UHI-SBG-0 Housing is smartly styled for indoor use. This housing meets customers' demands for attractive housings that are both cost competitive and easy to install. They fit a wide range of 1/4 in., 1/3 in., and 1/2 in. format CCD cameras and varifocal lenses.

Functions

The design of these housings is unique. Removal of two tamper-resistant screws is all that is necessary to open the cover and totally expose the camera and lens. This allows access to all camera and lens controls when the camera is in its mounted position. Power and video cabling can be routed through liquid tight fittings in the bottom or rear of the housing. To complete this set, a sturdy aluminum feed-through mount is added.

Certifications and Approvals

Product Safety

CE, UL, cUL

Installation/Configuration Notes

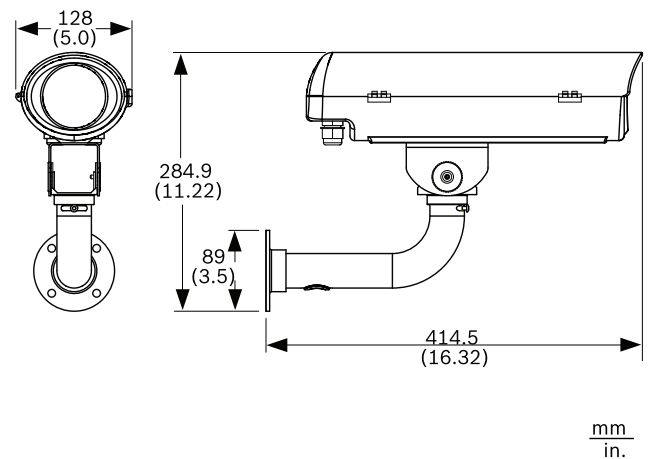

Parts Included

Quantity	Component
1	Indoor housing
1	Aluminum bracket

Technical Specifications

Electrical

Maximum Camera Power Max. 10 W
 24 VAC–230 VAC, 50/60 Hz, 0.5 A

Mechanical

Max Camera/Lens Size (W x H x L)	80 x 60 x 210 mm (3.1 x 2.3 x 8.2 in.)
Cable Entry	Two liquid tight rear fittings accept cable diameters from 6.5 mm to 10.5 mm (0.26 in. to 0.42 in.). Two bottom feed-through liquid tight fittings accept cable diameters from 4.0 mm to 7.0 mm (0.16 in. to 0.28 in.).
Window	3 mm (0.12 in.) thick glass.
Housing Mounting	Includes one J-mount. Four (4) available 1/4 -20 tapped holes.
Camera Mounting	Removable camera bracket. Mounted with one screw.
Construction/Finish	Reinforced with glass fiber ABS, stainless steel hardware.
Finish	Dark mushroom.
Dimensions	See UHI-SBG-0 drawing.
Weight	1.0 kg (2.2 lb) including bracket.

Environmental

Temperature -10°C (14°F) to 50°C (122°F)
 Enclosure Protection IP30 (indoor use only)

Ordering Information

UHI-SBG-0 Series Indoor Housing	UHI-SBG-0
For camera/lens lengths up to 210 mm (8.2 in.)	

Accessories

HAC-TAMP01 Tamper Switch	HAC-TAMP01
Tamper switch kit for HSG and UHI/UHO series enclosures	

Americas:
 Bosch Security Systems, Inc.
 130 Perinton Parkway
 Fairport, New York, 14450, USA
 Phone: +1 800 289 0096
 Fax: +1 585 223 9180
 security.sales@us.bosch.com
 www.boschsecurity.us

Europe, Middle East, Africa:
 Bosch Security Systems B.V.
 P.O. Box 80002
 5600 JB Eindhoven, The Netherlands
 Phone: + 31 40 2577 284
 Fax: +31 40 2577 330
 emea.securitysystems@bosch.com
 www.boschsecurity.com

Asia-Pacific:
 Robert Bosch (SEA) Pte Ltd, Security Systems
 11 Bishan Street 21
 Singapore 573943
 Phone: +65 6258 5511
 Fax: +65 6571 2698
 apr.securitysystems@bosch.com
 www.boschsecurity.com

Represented by